

Standard Symbol

BMP Objectives

- Soil Stabilization
- Sediment Control
- Tracking Control
- Wind Erosion Control
- Non-Storm Water Management
- Materials and Waste Management

Definition and Purpose

Devices used at storm drain inlets that are subject to runoff from construction activities to detain and/or to filter sediment-laden runoff to allow sediment to settle and/or to filter sediment prior to discharge into storm drainage systems or watercourses.

Appropriate Applications

- Where ponding will not encroach into highway traffic.
- Where sediment laden surface runoff may enter an inlet.
- Where disturbed drainage areas have not yet been permanently stabilized.
- Where the drainage area is 0.4 ha (1 ac) or less.
- Appropriate during wet and snow-melt seasons.

Limitations

- Requires an adequate area for water to pond without encroaching upon traveled way and should not present itself to be an obstacle to oncoming traffic.
- May require other methods of temporary protection to prevent sediment-laden storm water and non-storm water discharges from entering the storm drain system.
- Sediment removal may be difficult in high flow conditions or if runoff is heavily sediment laden. If high flow conditions are expected, use other on-site sediment trapping techniques (e.g. check dams) in conjunction with inlet protection.
- Frequent maintenance is required.
- For drainage areas larger than 0.4 ha (1 ac), runoff shall be routed to a sediment trapping device designed for larger flows. See BMPs SC-2, "Sediment/Desilting Basin," and SC-3 "Sediment Trap."

- Filter fabric fence inlet protection is appropriate in open areas that are subject to sheet flow and for flows not exceeding 0.014 m³/s (0.5 cfs).
- Gravel bag barriers for inlet protection are applicable when sheet flows or concentrated flows exceed 0.014 m³/s (0.5 cfs), and it is necessary to allow for overtopping to prevent flooding.
- Fiber rolls and foam barriers are not appropriate for locations where they cannot be properly anchored to the surface.
- Excavated drop inlet sediment traps are appropriate where relatively heavy flows are expected and overflow capability is needed.

Standards and Specifications

Identify existing and/or planned storm drain inlets that have the potential to receive sediment-laden surface runoff. Determine if storm drain inlet protection is needed, and which method to use.

Methods and Installation

- **DI Protection Type 1 - Filter Fabric Fence** - The filter fabric fence (Type 1) protection is illustrated on Page 5. Similar to constructing a silt fence. See BMP SC-1, "Silt Fence." Do not place filter fabric underneath the inlet grate since the collected sediment may fall into the drain inlet when the fabric is removed or replaced.
- **DI Protection Type 2 - Excavated Drop Inlet Sediment Trap** - The excavated drop inlet sediment trap (Type 2) is illustrated in Page 6. Similar to constructing a temporary silt fence, See BMP SC-1, "Silt Fence." Size excavated trap to provide a minimum storage capacity calculated at the rate of 130 m³/ha (67 yd³/ac) of drainage area.
- **DI Protection Type 3 – Gravel bag** - The gravel bag barrier (Type 3) is illustrated in Page 7. Flow from a severe storm shall not overtop the curb. In areas of high clay and silts, use filter fabric and gravel as additional filter media. Construct gravel bags in accordance with BMP SC-6, "Gravel Bag Berm." Gravel bags shall be used due to their high permeability.
- **DI Protection Type 4 – Foam Barriers and Fiber Rolls** – Foam barrier or fiber roll (Type 4) is placed around the inlet and keyed and anchored to the surface. Foam barriers and fiber rolls are intended for use as inlet protection where the area around the inlet is unpaved and the foam barrier or fiber roll can be secured to the surface. RE or Construction Storm Water Coordinator approval is required.

Maintenance and Inspection

General

- Inspect all inlet protection devices before and after every rainfall event, and weekly during the rest of the rainy season. During extended rainfall events, inspect inlet protection devices at least once every 24 hours.

- Inspect the storm drain inlet after severe storms in the rainy season to check for bypassed material.
- Remove all inlet protection devices within thirty days after the site is stabilized, or when the inlet protection is no longer needed.
 - Bring the disturbed area to final grade and smooth and compact it. Appropriately stabilize all bare areas around the inlet.
 - Clean and re-grade area around the inlet and clean the inside of the storm drain inlet as it must be free of sediment and debris at the time of final inspection.

Requirements by Method

■ ***Type 1 - Filter Fabric Fence***

- This method shall be used for drain inlets requiring protection in areas where finished grade is established and erosion control seeding has been applied or is pending.
- Make sure the stakes are securely driven in the ground and are structurally sound (i.e., not bent, cracked, or splintered, and are reasonably perpendicular to the ground). Replace damaged stakes.
- Replace or clean the fabric when the fabric becomes clogged with sediment. Make sure the fabric does not have any holes or tears. Repair or replace fabric as needed or as directed by the RE.
- At a minimum, remove the sediment behind the fabric fence when accumulation reaches one-third the height of the fence or barrier height. Removed sediment shall be incorporated in the project at locations designated by the RE or disposed of outside the highway right-of-way in conformance with the Standard Specifications Section 7-1.13.

■ ***Type 2 – Excavated Drop Inlet Sediment Trap***

- This method may be used for drain inlets requiring protection in areas that have been cleared and grubbed, and where exposed soil areas are subject to grading.
- Remove sediment from basin when the volume of the basin has been reduced by one-half.

■ ***Type 3 - Gravel Bag Barrier***

- This method may be used for drain inlets surrounded by AC or paved surfaces.
- Inspect bags for holes, gashes, and snags.

- Check gravel bags for proper arrangement and displacement. Remove the sediment behind the barrier when it reaches one-third the height of the barrier. Removed sediment shall be incorporated in the project at locations designated by the RE or disposed of outside the highway right-of-way in conformance with the Standard Specifications Section 7-1.13.
- ***Type 4 Foam Barriers and Fiber Rolls***
 - This method may be used for drain inlets requiring protection in areas that have been cleared and grubbed, and where exposed soil areas subject to grading. RE or Construction Storm Coordinator approval is required.
 - Check foam barrier or fiber roll for proper arrangement and displacement. Remove the sediment behind the barrier when it reaches one-third the height of the barrier. Removed sediment shall be incorporated in the project at locations designated by the RE or disposed of outside the highway right-of-way in conformance with the Standard Specifications.

Storm Drain Inlet Protection

SC-10

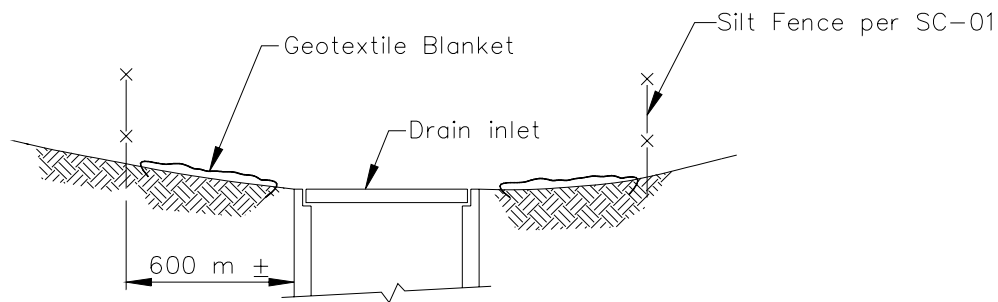

SECTION A-A

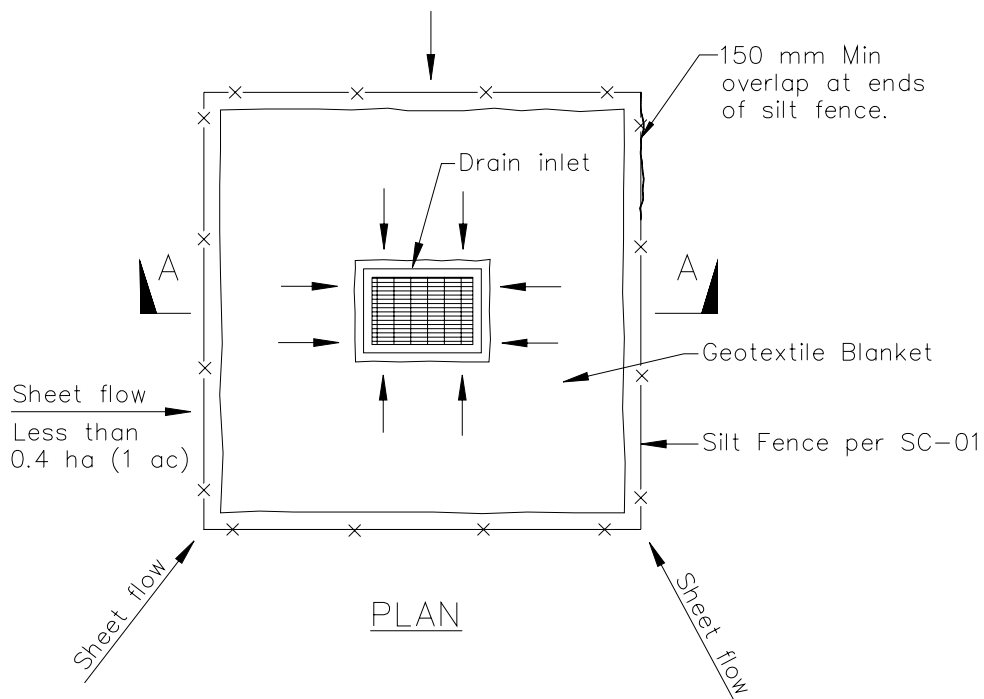

PLAN

DI PROTECTION TYPE 1
NOT TO SCALE

NOTES:

1. For use in areas where grading has been completed and final soil stabilization and seeding are pending.
2. Not applicable in paved areas.
3. Not applicable with concentrated flows.

Storm Drain Inlet Protection

SC-10

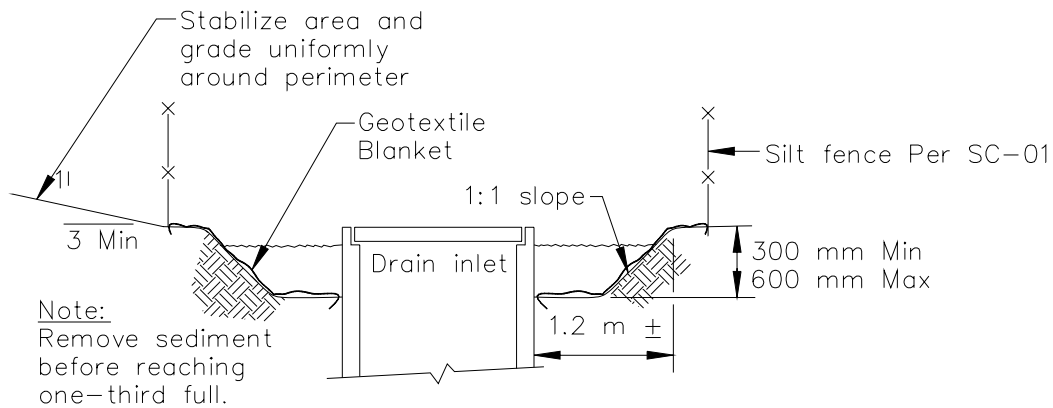

Section A-A

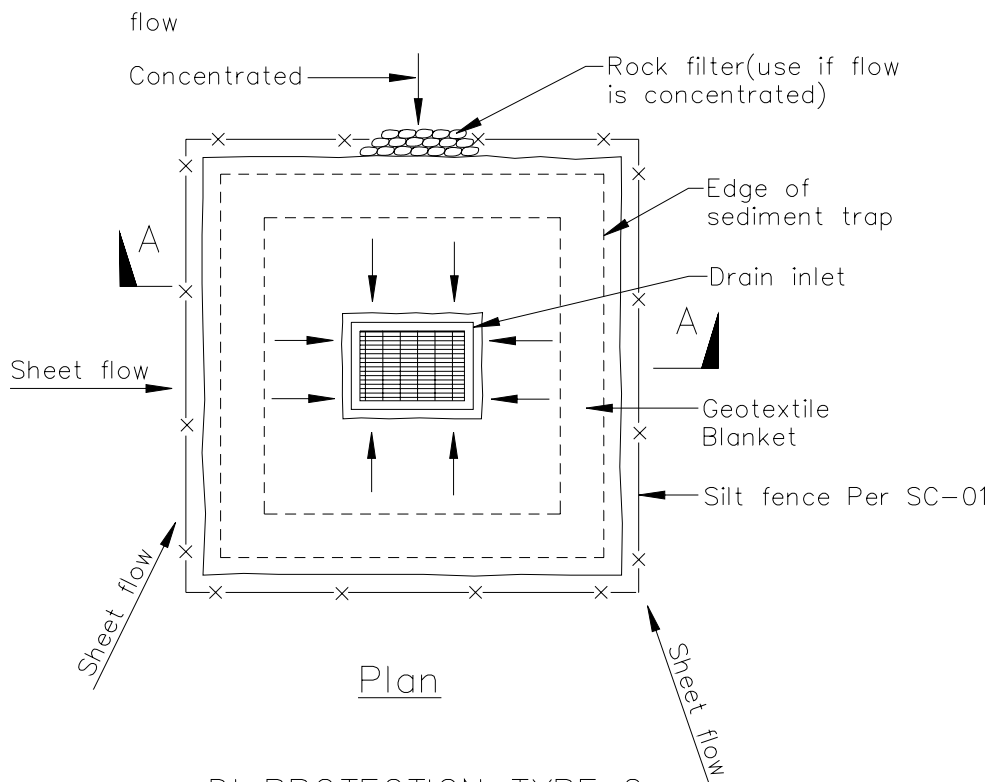

Plan

DI PROTECTION TYPE 2
NOT TO SCALE

Notes

1. For use in cleared and grubbed and in graded areas.
2. Shape basin so that longest inflow area faces longest length of trap.
3. For concentrated flows, shape basin in 2:1 ratio with length oriented towards direction of flow.



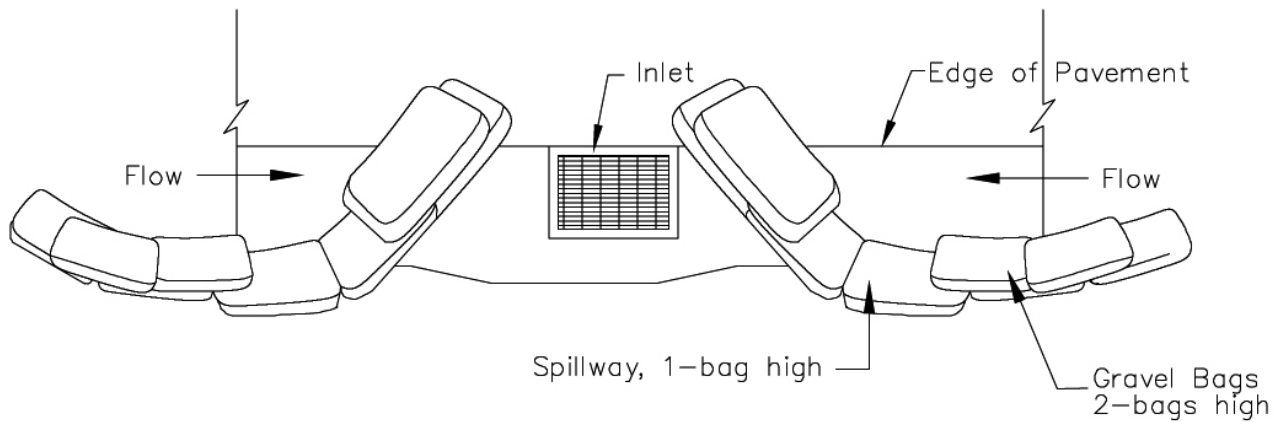

TYPICAL PROTECTION FOR INLET WITH OPPOSING FLOW DIRECTIONS

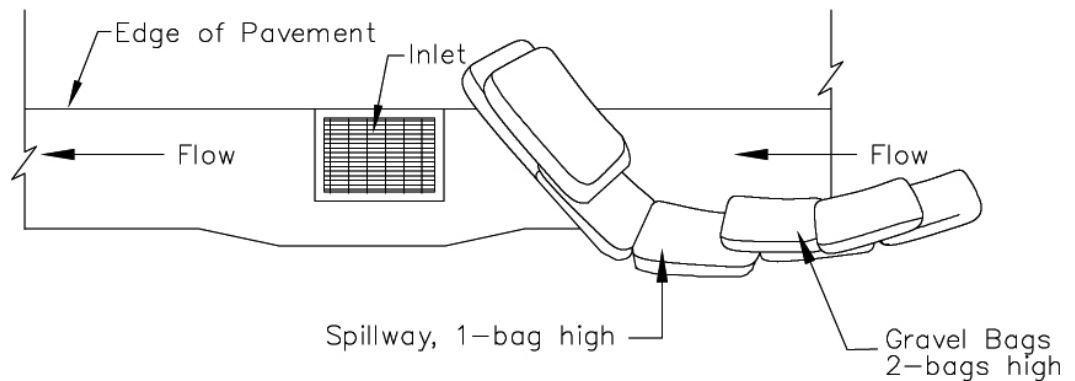

TYPICAL PROTECTION FOR INLET WITH SINGLE FLOW DIRECTION

NOTES:

1. Intended for short-term use.
2. Use to inhibit non-storm water flow.
3. Allow for proper maintenance and cleanup.
4. Bags must be removed after adjacent operation is completed
5. Not applicable in areas with high silts and clays without filter fabric.